



## LOW LOADING – ST SERIES

The ST-series is the most popular series of DEMARKO semi-trailers with the most versatile profile. The multitude of modifications and accessories offered by ST-series semi-trailers ensure their multi-functionality and efficiency in oversize transport. The modular design enables multiple length and width extensions. When the semi-trailer is extended, its functionality is ensured by for example an intermediate table that, depending on the dimensions, may be equipped with stanchion sockets, telescopic width extensions and even cavities for the wheels of construction machines. Various variants of axle assembly support a series of configurations, enabling even hydraulic-assisted turns controlled by a wireless remote.

The functionality of DEMARKO low-loading semi-trailers is ensured by for example:

- an intermediate table that, depending on the dimensions, may be equipped with stanchion sockets, telescopic width extensions and even cavities for the wheels,
- wheels of the construction machines (which may be filled when transporting other loads),
- a load trestle that aligns the level of the lower load deck with the balcony when transporting long loads,
- aluminium ramps, which may be installed in the rear of the semi-trailer or at the swan neck,
- load security features in the form of aluminium sides on the neck, steel stanchions inserted into sockets on the deck and the semi-trailer profile, as well as belts with tensioners, using a series of fixtures to secure the load,
- tool cases installed on the front wall and under the semi-trailer,
- compartments for stanchions and aluminium ramps.

ST Series offers the most choice of options and modifications, which is reflected also by the multitude of selections with regard to the number of axles. In total, we manufacture as many as 10 variants, 2 to 10 axles, including the 3-axle light version and two 8-axle variants.

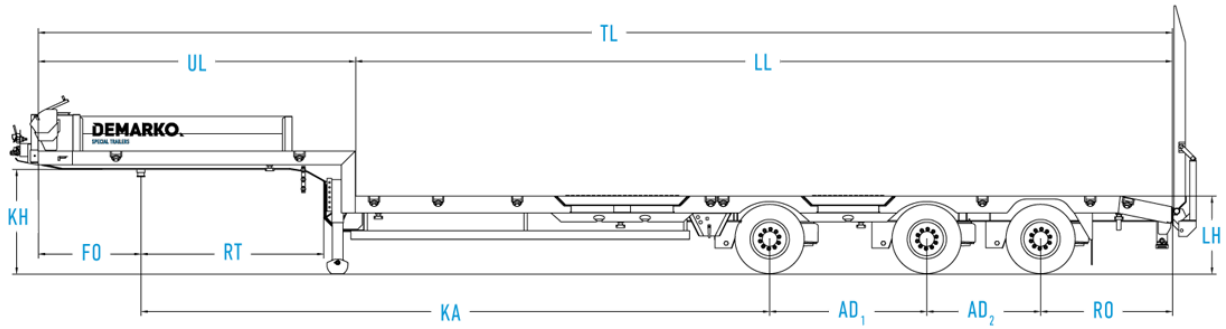

## ST – 3 AXLE LIGHT

### MAIN DIMENSIONS

<b>TL</b>	Total length	13.060 mm
<b>W</b>	Width	2.540 mm
<b>KH</b>	Kingpin height	1.180 mm
<b>LH</b>	Loading area height	890 mm
<b>LL</b>	Lower loading area length	9.405 mm
<b>UL</b>	Upper loading area length	3.655 mm
<b>FO</b>	Front overhang	1.180 mm
<b>RO</b>	Rear overhang	1.520 mm
<b>RT</b>	Swing clearance radius for truck	2.105 mm
<b>RA</b>	Clearance radius for trailer	1.495 mm
<b>AD1/AD2</b>	Axle distance	1.810/1.360 mm
<b>KA</b>	Distance from kingpin to the 1st axle	7.240 mm

### WEIGHT

Max. fifth wheel load	18.000 kg
Axle load capacity	30.000 kg
Gross vehicle weight	48.000 kg
Dead weight	7.950 kg
Payload	40.050 kg

All dimensions and weights are approximate and may vary depending on configuration and choice of accessories. Changes in construction and equipment are reserved. There may be some differences between the versions placed on the market in different countries.